

TOSHIBA



With Ex e, Ex n & DIP Options

TOTALLY ENCLOSED FAN COOLED
PREMIUM EFFICIENCY
HEAVY DUTY ELECTRIC MOTORS

0.37kW to 355kW • 200volt to 1100volt

S O L U T I O N S • S E R V I C E • S U P P O R T



N1971

TOSHIBA INTERNATIONAL CORPORATION PTY LTD



STANDARD PREMIUM EFFICIENCY* MOTOR FEATURES INCLUDE

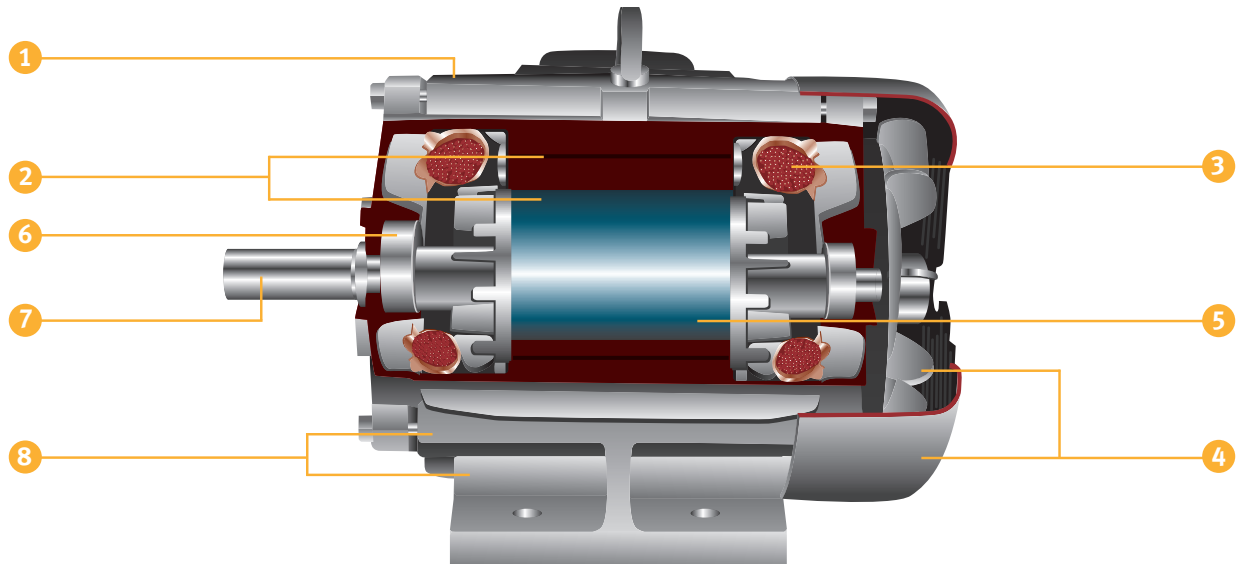

HEAVY DUTY CONSTRUCTION ①

- Frames are high grade cast iron,
 - Machined to close tolerance to ensure accurate alignment and fit in accordance with our high standards.
 - Exceptional corrosion resistance & high structural rigidity are inherent in Toshiba motor construction.
- Steel fan covers are standard with cast iron option.
- Sintered bronze drain plugs are fitted as standard for frames D160 and above. Available as an option on smaller frames.

STANDARDS

- Toshiba Premium Efficiency Motors comply with AS1359 and MEPS 2006 requirements.
- Special motors to other Standards are also available eg NEMA, CENELEC or other national standards.

PREMIUM EFFICIENCY LAMINATIONS ②

- Premium-grade silicon steel and longer cores lower operating flux densities and losses achieving optimum efficiency.

LOW LOSS STATOR WINDINGS ③

- Toshiba's use of greater cross sectional area of copper lowers winding resistance and reduces losses giving improved efficiency.
- All windings are insulated with non-hygroscopic materials, ensuring reliable motor operation in humid, corrosive and abrasive industrial environments.

INSULATION & THERMAL ADVANTAGE

- Toshiba motors are insulated with class 'F' materials and feature excellent thermal reserve, offering low temperature rise characteristics generally below class 'E'.
- These characteristics allow optimal flexibility in regard to variable frequency drives, higher altitude and higher ambient applications, and are also forgiving to intermittent current overloads.

FLEXIBLE TERMINAL BOX DESIGN

- Cast iron terminal boxes are diagonally split, and have flanges and neoprene gaskets. Larger frames have oversized fabricated steel boxes.
- All terminal boxes are fitted with removable gland plates, drilled and tapped to dimensions specified on pages 10-13. Blank or customised gland plates are available as an option.
- Terminal boxes may be rotated 90° by four positions for conduit entry on frames smaller than D315.
- Terminal boxes are mounted right hand side, viewed from drive end, and can be mounted on the opposite side if required on frames up to D225. On frames D250 and above, for non-standard terminal box positions contact Toshiba office at time of order.

LOW NOISE LEVELS ④

- Special attention to the fan and cowl design achieves quiet operation with efficient cooling. Toshiba can supply motors with special low noise level fans and/or acoustic covers.
- Fans are cast iron or fabricated steel depending on frame size.

HIGH TORQUE ROTOR ⑤

- Pressure cast aluminium rotors with integrally cast bars, end rings and cooling fans, provide reliable operation.
- Specially designed rotors give Toshiba motors advantageous torque characteristics and minimise losses.

LONG LIFE BEARINGS ⑥

- The use of oversized bearings assures long life and quiet operation. Motors in frame sizes up to D132 have sealed bearings. Larger sizes have regreaseable bearings.

HARDWARE

- All fastenings are zinc passivated for resistance to corrosion.
- Threads are metric.



OUTPUT SHAFTS 7

- Output shafts are fitted with water/dust excluders.

DURABLE NAMEPLATE

- Stainless steel nameplate provides complete motor ratings including bearing sizes for quick reference.

CORROSION RESISTANT FINISH 8

- Toshiba motors are Phenol Resin primed and finished with Polyurethane semi-gloss. Standard colour is Wood Smoke Grey. Customer specified colours and paint finishes available.

CONNECTIONS

- All motors are fitted with stud type terminal blocks with 6 (terminations) winding leads. Motors in frames D112 and below may be configured for 220V-240V Delta or 380V-415V Star operation, suitable for VVVF Drives. Motors in larger frames are suitable for Direct-on-line, Auto-transformer, Star-Delta, Soft Starter and VVVF Drives with 380V-415V supplies.
- Thermistors are fitted as standard on motors, frame D160 and above and can be fitted on smaller sizes if specified. Thermistor terminals are marked T1, T2.
- An earthing terminal is provided inside the main terminal box, with an additional external earthing facility on all frames.

- Toshiba motors can be supplied wound for voltages up to 1100 volts.

ORDERING

- When ordering please nominate: kW, rpm, enclosure classification (IP rating), mountings type, e.g. foot, flange or foot and flange, horizontal or vertical, shaft (shaft direction up or down etc).
- If in doubt about motor selection, please provide starting and application details.
- Give details of any additional specification or requirements.

DRIVE APPLICATIONS

- Motors 4 pole and slower are generally suitable for normal vee-belt drive. Motors of higher speeds are generally for direct coupling only. For confirmation of application suitability, please contact Toshiba.
- 2 Pole motors with frames D315 and above have unidirectional fans, normally set for clockwise rotation when viewed from the drive end (CCW fans also available), therefore direction of rotation for these motors should be stated at time of enquiry.

EXAMPLES OF COMMON MOUNTING ARRANGEMENTS

FOOT MOUNTED MOTOR:
2 bearings, shaft with one free extension, stator frame with feet.

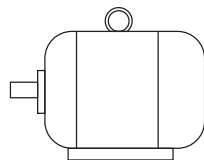

IM 1001 – B3

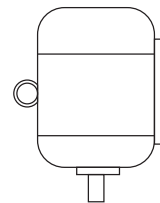

IM 1011 – V5

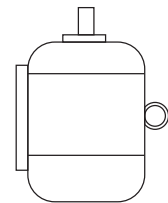

IM 1031 – V6

FLANGE MOUNTED MOTOR:
2 bearings, shaft with one free extension, stator frame without feet, large flange with clearance fixing holes.

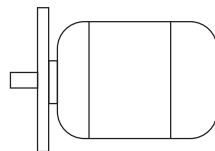

IM 3001 – B5

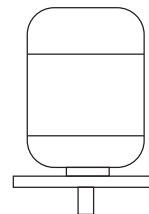

IM 3011 – V1

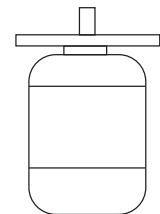

IM 3031 – V3

FOOT AND FLANGE MOUNTED MOTOR:
2 bearings, shaft with one free extension, stator frame with feet, large flange with clearance fixing hole.

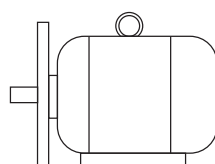

IM 2001 – B35

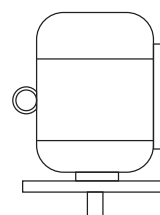

IM 2011 – V15

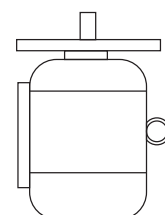

IM 2031 – V36



LOW VOLTAGE MOTOR RANGES



PREMIUM EFFICIENCY MOTOR

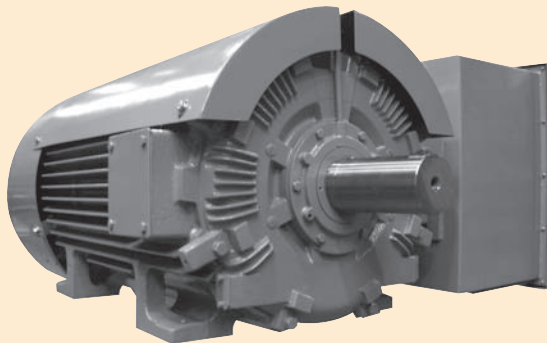

LARGE HEAVY DUTY MOTOR - HIGH EFFICIENCY

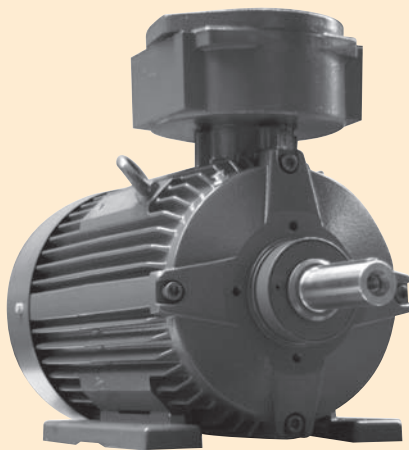

EXPLOSION PROTECTED MOTOR

PREMIUM EFFICIENCY MOTORS

(Premium Efficiency)

Ratings: 0.37kW to 800kW (200V - 1100V)
2,4,6,8 Pole (Specials Available)
Protection Classification IP56 - IP66

Benefits: High starting torque with low starting current ensures premium performance under arduous load conditions. Easily adapted for VVVF control or reduced voltage starting, this range offers a high degree of flexibility in application while providing efficient performance.

LARGE HEAVY DUTY MOTORS

(High Efficiency) - Motors Above AS1359.30

Ratings: 185kW to 800kW (200V - 1100V)
2,4,6, 8 Pole (Specials available)
Protection classification IP55 - IP66

Benefits: Designed and built for Heavy Duty Industrial applications. Adaptable for VVVF control or reduced voltage starting, this range offers a high degree of flexibility in application.

HAZARDOUS AREA MOTORS

Both, Premium Efficiency and High Efficiency Motor ranges are suitable for modification to comply with Hazardous Area classifications and are certified to current Australian and IEC Standards. Refer to table on page 7, for more detail.

EXPLOSION PROTECTED MOTORS

Ratings: 0.37kW to 700kW (200V - 1100V)
2,4,6,8 Pole (Specials Available)
Ingress Protection Classification IP55 - IP66
Ex d certified to current Australian and IEC Standards including Group 1 mining.

Benefits: Suitable for Industrial applications such as mining and petrochemical. Versatile construction, side or top mounting of terminal box, foot, foot & flange and flange mounting options. Modifications to satisfy individual customer requirements and specifications. Refer to Toshiba's Flameproof Catalogue.

SPECIAL MOTORS

Toshiba offers a range of motors to suit individual customer requirements. Special applications include - Multi Speed Motors, Brake Motors, Direct Current Motors, Open Drip Proof Motors, Wound Rotor Motors, Variable Speed Motors, CENELEC and NEMA standard motors and most special application motors.



GENERAL INFORMATION

DEFINITIONS AND FORMULE

Power: Power is the rate of doing work and in metric system, it is expressed in Watts (W) or often in kilowatts (kW).

Output Power of 3-Ph Electrical Motor:

$$P \text{ (kW)} = \frac{(1.732 \times \text{Line Voltage} \times \text{Line Current} \times \text{p.f.} \times (\text{Motor Eff.}/100))}{1000}$$

$$P \text{ (kW)} = 0.746 \times \text{Horsepower}$$

Torque: Torque is a twisting force about an axis of rotation. It is measured in units of force times distance from the axis (Nm). For an electric motor, Torque is its turning capacity and hence, its most useful characteristic.

Torque and Power are related to each other by the following equation:

$$\text{Power (kW)} = \frac{\text{Torque (Nm)} \times \text{Speed (rpm)}}{9550}$$

Inertia: Inertia is the name for the tendency of an object in motion to remain in motion. Typically for cylindrical objects, it is given by:

$$GD^2 \text{ (kg-m}^2\text{)} = 1/2 \times \text{Mass} \times (\text{Diameter})^2$$

Acceleration Time Acceleration Time of a motor is related to Total Inertia at the motor shaft as well as Acceleration Torque by the following equation:

$$\text{Acc. Time (sec)} = \frac{GD^2 \text{ (kg-m}^2\text{)} \times \text{Change in Speed (rpm)}}{375 \times \text{Acc. Torque (Nm)}}$$

Acc. Torque of a motor can be approximated as follows:

For Constant Torque Loads (e.g. Conveyors, Mixers etc)	$T_{acc} = 0.4(T_s + T_b) - T_L$
For Quadratic Torque Loads (Cent. Fans / Pumps)	$T_{acc} = 0.4(T_s + T_b) - 0.33 \times T_L$

Where T_s = Starting Torque , T_b = Breakdown Torque ,
 T_L = Load Torque at Motor Shaft.
 T_{acc} = acc. time (sec).

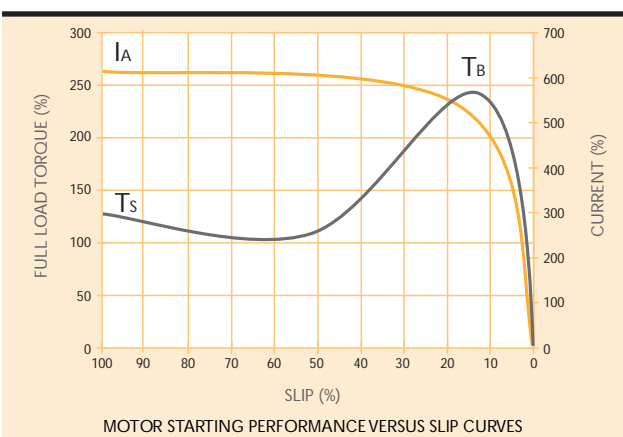

MOTORS WITH VVVF DRIVES

More and more motors in industries are getting driven by VVVF drives for accurate speed control. While accurate speed control results into better product quality end product and/or saving of energy, performance of motors with VVVF drives is considerably different than when they are fed directly by mains supply.

Unless the motors have separate forced fan-cooling, reduced speeds requires that their outputs are re-rated to allow generated heat to be adequately dissipated. This is of particular importance when motors are running at very slow speeds but still requiring constant torques through out the speed range.

Further, unlike the mains supply, VVVF supply voltage is non-sinusoidal and is often in the form chopped waveforms. This pulse Width Modulated (PWM) waveform has detrimental effects on motor torque capability as well as its thermal characteristics. This also calls for additional de-rating of its output. PWM chopped waveform also leads other motor issues such as:

- Decreased Insulation life due to dv/dt effects as well as increased voltage levels at the motor terminals due to reflected waves
- Increased noise levels – especially at low VVVF carrier frequencies
- Reduced bearing life through Electric Discharge Machining (EDM) effects.
- Motor over-heating due to harmonics in PWM waveform
- Possibility of generating shaft currents

As with most applications, proper investigation during project conceptualization, as well as prior to actual installation, often saves considerable time and money in solving some of the above mentioned issues.

With vast experience of Toshiba engineers, cost effective and reliable Motor-Drive solutions can be ensured. Following information helps in selecting the most optimum solution:

- Type of Load / Application (e.g. Conveyor/Fan/Pump/Mixer etc)
- KW and Torque required in the required speed range
- Supply Voltage and Frequency with their tolerances
- Environmental Conditions (Temperature/Hazardous Area etc)
- Cable length from VVVF to the motor

ELECTROMAGNETIC COMPATIBILITY

Toshiba motors and VVVF Drives comply to Electromagnetic Compatibility (EMC) regulations as per Australian C-Tick Scheme.



MOTORS FOR HAZARDOUS AREAS

Toshiba offers the widest range of Hazardous Area certified motors in Australia.

Both our Premium Efficiency and Energy Efficient motor ranges are certified for modification for use in hazardous areas as per tables 1 and 2 on page 7.

SOME TYPICAL AREAS OF USE

- Petrochemical, Mining, Oil & Gas, Chemical.

FLAMEPROOF Ex d



Motors are constructed so as to contain an internal explosion within the motor and prevent the transmission of flame to external atmosphere. External temperature during operation is kept such that the surrounding flammable atmosphere cannot be ignited.

CERTIFICATION AND APPROVALS

Toshiba's Flameproof motors are Ex d approved for explosive gas groups IIA, IIB & IIC for temperature class T4, and are also approved for underground Coal Mines, apparatus group I (methane).

For more information please refer to Toshiba's Flameproof Motor Catalogue.

INCREASED SAFETY Ex n



These motors are not built to withstand an internal explosion (flameproof). They are designed to ensure safety by means of a number of special features to ensure freedom from arcs, sparks or dangerous surface temperatures. They resemble standard motors in appearance but have special increased safety terminals within an IP56 terminal box.

The main features of increased safety motors are:

- Special attention to air gap concentricity and clearance of all rotating parts
- Components subject to impact tests
- Temperature rise 10°C lower than the permitted maximum for that class of insulation
- Maximum surface temperature T2 or T3
- Compliance with t_E characteristics
- Special terminal block to accommodate specified creepage and clearances
- Terminal block material ensures anti tracking

The maximum surface temperature (T) applies to all surfaces of the motor, both internal and external. Under locked rotor conditions, the rotor temperature in certain designs increases faster than that of the stator windings. In either event this is catered for in conjunction with the t_E time.

t_E TIME

t_E time is defined as the time taken for a.c. windings when carrying the starting current I_A to be heated up from temperature reached in rated service and at maximum ambient temperature, to the limiting temperature. In the graph below, 'A' represents the maximum ambient temperature and 'B' represents temperature reached under normal load. If fault occurs and the rotor becomes locked, then the conditions shown in part 2 of the graph will apply. The motor temperature will increase very rapidly to 'C', which is less than the T classification for the motor. The time taken to reach limiting temperature point 'c' from temperature level B is called t_E time. Control gear must be provided to disconnect the motor from the supply within this time t_E . These motors are certified and suitable for use in zone 1 and have a maximum temperature level of T3. They are intended for continuous running and are unsuitable for duties involving frequent starts/stops or long run-up times or VVVF operation.

TOSHIBA INTERNATIONAL CORPORATION PTY LTD					
INDUSTRIAL DIVISION AUSTRALIA		3-PHASE INDUCTION MOTOR			
kW	VOLTS		FRAME		
RPM	AMPS	Hz	IP		
CONNECT	INS. CLASS F	RATING	BRG.	DE.	
MAX AMB. °C	MODEL	std. AS1359	No.	NDE.	
I_A / I_n	t_E TIME	SEC	MASS kg	COS ϕ	
SERIAL No.					
AUS Ex 1174X		Ex e IIC	T	INCREASED SAFETY TO AS2380.6	
CERTIFIED FOR USE IN ZONE 1 HAZARDOUS AREA					
EXPLOSION PROTECTED IN AUSTRALIA					
PREMIUM EFFICIENCY					

Typical Ex e nameplate

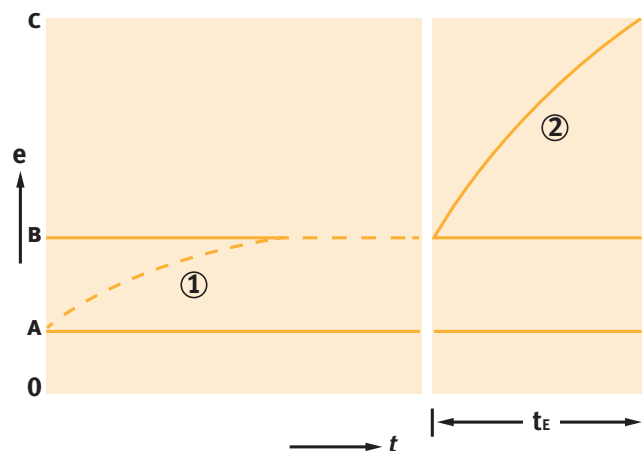

O = temperature °C

A = max. ambient temperature

B = temperature in rated service

C = limiting temperature

t = time

e = temperature

① = temperature rise in rated service

② = temperature rise during stalled motor test



NON SPARKING Ex n

These motors are for use in Zone 2 hazardous locations. The Ex n motor is very similar in construction to the TEFC machine. The main points of difference are:

- Special attention to air gap concentricity and clearance of all rotating parts
- Components subject to impact test
- Maximum internal or external surface temperature T3
- Terminal block material to ensure anti-tracking
- Special terminal block to stop creepage.

It can be observed that many of the above Ex n features are similar to type Ex e except that the standard outputs are obtained from these motors, i.e. no de-rating is involved. Because Ex n motors are used in Zone 2 semi-hazardous locations, internal and external surfaces are limited to T3 at all times except during the starting period.

Temperature class	T1	T2	T3	T4	T5	T6
Temperature limit °C	450	300	200	135	100	85

DUST-EXCLUDING IGNITION-PROOF DIP

These motors are built to exclude dust and to prevent, sparks or heat otherwise generated or liberated inside the enclosure to cause ignition of exterior accumulations or atmospheric suspensions of a specific dust on or in the vicinity of the enclosure.

Dust is excluded from the motor and terminal box enclosure and the exterior temperature is kept below the ignition temperature of a dust cloud or layer, up to 5mm thick. As a rule dust layering should be avoided.

Examples of such dusts are wood, starch, coal dust and grain dusts including flour, cocoa, sugar, milk powder and tea, as well as various metals and chemicals including bronze, zinc, sulphur and toner.

It should be noted that the distinction between dust types does not affect the selection of equipment for dust areas.

HAZARDOUS AREA CLASSIFICATION	
Zone 0	Zone where explosive atmosphere is continuously present for long periods (> 1000 Hrs)
Zone 1	Zone where explosive atmosphere is periodically present in normal operation (> 10 Hrs – 1000 Hrs)
Zone 2	Zone where explosive atmosphere is not likely to be present in normal operation and if present it exists for short periods only (< 10 Hrs)

GROUP CLASSIFICATION		HAZARD CLASSIFICATION	
Group 1	Coal Mines	Class 1	Gas
Group 2	Other	Class 2	Dust

GAS GROUPING FOR ELECTRICAL APPARATUS EN 50014 AND IEC 60079-0	
Group	Gas
I	All underground Coal Mining applications Firedamp (methane)
IIA	Industrial methane, propane, gasoline and most industrial gases
IIB	Ethylene, coke oven gas and other industrial gases
IIC	Hydrogen, acetylene, carbon disulphide

TYPICAL TIC AUSTRALIAN / IEC STANDARD EXPLOSION PROTECTED CERTIFICATES				
TYPE OF HAZARD	EXPLOSIVE GASES			EXPLOSIVE DUSTS
Area of Classification	Zone 1 or 2 (Class 1)		Zone 2 (Class 1)	Zone 21 (DIV 1) Zone 22 (DIV 2)
Type of Motor Protection	Explosion Protected Ex d	Increased Safety Ex e	Non-Sparking Ex n	Dust Ignition Proof DIP
*Toshiba Certifications of Compliance	AUS Ex 00.3695X	AUS Ex 1174X	IEC Ex TSA 09.0034X	AUS Ex 1078X
	AUS Ex 00.3697X			
	AUS Ex 00.3698X			
Apparatus Group	IIA, IIB & IIC (including GROUP I Mining)	IIA, IIB & IIC	IIA, IIB & IIC	ZONE 21 & 22
Temperature Class	T4 (options T5 & T6)	T3 (and T2)	T3	T4
Referenced Standards	IEC 60079 AS/NZS 60079.1	AS/NZS 60079.7	IEC 60079 AS/NZS 60079.15	ANZS 61241



PERFORMANCE DATA

PREMIUM EFFICIENCY PERFORMANCE DATA AT 415V - 50Hz

Output kW	RPM	Frame Number	Full Load Current (A)			No Load Current (A)	Locked Rotor Current (%) F/L	Locked Rotor Torque (%) F/L	Pull Up Torque (%) F/L	Break Down Torque (%) F/L	Efficiency (%)			Power Factor			Rotor GD ² (kg.m ²)	Sound Pressure dB(A) at 1 metre
			@ 415V	@ 400V	@ 380V						Full Load	75% Load	50% Load	Full Load	75% Load	50% Load		
0.37	2830	D71	0.95	0.87	0.89	0.68	521	378	300	470	73.9	72.6	68.5	0.74	0.64	0.52	0.01	67
	1410	D71M	1.05	1.05	1.05	0.79	571	383	306	396	75.5	73.9	69.1	0.65	0.56	0.43	0.01	56
	900	D80	1.10	1.10	1.10	0.81	405	279	223	309	73.6	74.0	71.7	0.65	0.55	0.42	0.01	49
	675	D90SL	1.40	1.40	1.40	1.11	333	199	179	232	67.1	65.5	60.1	0.54	0.46	0.36	0.02	45
0.55	2805	D71	1.18	1.19	1.22	0.64	594	226	190	300	77.4	78.4	77.0	0.84	0.76	0.63	0.01	67
	1430	D80	1.32	1.32	1.33	0.95	784	433	350	481	80.8	79.4	75.2	0.72	0.62	0.48	0.01	56
	895	D80	1.62	1.62	1.62	1.26	406	311	249	328	74.2	74.8	72.5	0.64	0.53	0.40	0.01	51
	700	D90LL	1.90	1.90	1.90	1.50	375	234	211	257	73.2	72.1	67.6	0.55	0.46	0.35	0.03	48
0.75	2845	D80	1.6	1.6	1.6	0.9	850	450	370	537	81.6	80.8	77.5	0.81	0.73	0.61	0.01	55
	1425	D80	1.8	1.7	1.8	1.2	725	406	355	426	82.2	81.5	78.3	0.73	0.64	0.50	0.01	53
	945	D90SL	2.0	2.0	2.0	1.4	505	215	201	304	81.1	81.5	79.2	0.65	0.55	0.42	0.02	55
	705	D100L	2.2	2.2	2.2	1.6	430	202	182	273	79.5	79.5	76.8	0.60	0.51	0.39	0.04	49
1.1	2855	D80	2.2	2.2	2.3	1.1	857	432	372	447	83.8	83.7	81.1	0.84	0.77	0.65	0.01	66
	1420	D90SL	2.5	2.4	2.6	1.3	664	326	315	349	84.7	85.5	84.5	0.77	0.69	0.56	0.02	57
	935	D90LL	2.7	2.7	2.8	1.6	490	215	196	255	80.9	81.5	79.5	0.71	0.63	0.50	0.03	57
	695	D100L	3.2	3.2	3.3	2.2	397	198	178	209	78.7	79.4	77.4	0.61	0.53	0.41	0.05	51
1.5	2875	D90SL	2.7	2.8	2.9	1.0	802	303	235	379	87.4	88.2	87.6	0.87	0.83	0.73	0.01	64
	1420	D90LL	3.3	3.3	3.4	1.9	675	358	286	390	86.2	87.1	86.3	0.74	0.66	0.52	0.02	53
	945	D100L	3.5	3.5	3.6	2.2	571	300	282	350	85.0	85.3	82.8	0.70	0.62	0.49	0.05	51
	710	D112ML	4.0	4.0	4.1	2.0	499	190	160	275	85.3	86.0	85.0	0.61	0.53	0.40	0.08	55
2.2	2875	D90LL	3.9	4.0	4.2	1.4	915	351	276	362	88.7	89.4	88.9	0.89	0.84	0.75	0.01	63
	1425	D100L	4.4	4.4	4.6	2.1	727	302	261	388	87.1	87.7	86.9	0.81	0.74	0.62	0.04	57
	960	D112ML	4.6	4.7	4.8	2.8	652	325	263	481	88.2	88.4	87.8	0.75	0.67	0.53	0.08	59
	715	D132S	5.0	5.0	5.1	3.2	584	231	208	290	84.1	83.6	81.0	0.73	0.65	0.52	0.19	55
3	2910	D100L	5.4	5.5	5.7	2.0	898	329	256	382	88.3	88.2	86.5	0.88	0.85	0.76	0.03	73
	1430	D100L	5.9	6.0	6.1	3.0	785	341	317	369	87.2	87.8	86.7	0.81	0.74	0.62	0.05	57
	970	D132S	6.7	6.5	6.7	3.6	681	237	233	381	89.0	89.5	88.3	0.73	0.65	0.52	0.16	53
	715	D132M	6.7	6.8	6.9	4.2	601	221	199	322	84.7	84.3	81.8	0.73	0.65	0.52	0.24	56
4	2905	D112ML	7.0	7.2	7.7	2.5	860	258	210	365	89.4	90.2	90.0	0.88	0.84	0.75	0.03	67
	1450	D112ML	7.8	8.0	8.2	3.7	746	323	258	363	88.3	88.5	87.3	0.80	0.75	0.64	0.08	66
	965	D132M	8.1	8.3	8.6	3.9	643	224	221	322	88.7	89.5	89.2	0.77	0.71	0.60	0.18	57
	730	D160M	10.0	10.0	10.2	6.2	441	186	167	209	86.7	86.8	85	0.64	0.56	0.44	0.35	56
5.5	2915	D132S	10.0	10.0	10.5	2.9	679	263	254	308	91.3	91.5	90.3	0.86	0.84	0.77	0.07	64
	1460	D132S	10.2	10.4	10.9	3.8	737	264	211	319	90.5	90.7	89.4	0.83	0.79	0.69	0.16	53
	965	D132M	11.7	11.5	11.8	5.8	689	263	260	374	89.6	90.3	89.9	0.76	0.69	0.56	0.22	58
	720	D160M	12.6	12.9	13.4	6.6	429	163	139	210	88.4	89.1	88.6	0.69	0.62	0.51	0.51	58
7.5	2915	D132S	12.9	13.3	14.0	3.5	802	242	194	355	91.7	91.7	91.1	0.88	0.86	0.81	0.08	61
	1455	D132M	14.7	14.8	15.2	6.5	694	288	230	317	91.1	91.5	90.8	0.78	0.73	0.62	0.19	55
	970	D160M	14.6	15.0	15.7	6.3	524	198	184	276	91.1	91.9	92.0	0.79	0.74	0.63	0.51	58
	720	D160L	18.0	18.2	18.6	10.3	428	160	144	231	87.9	88.6	87.8	0.66	0.59	0.47	0.59	68
11	2925	D160M	18.1	18.8	19.8	4.1	702	216	147	311	92.6	92.9	92.3	0.91	0.90	0.86	0.18	77
	1465	D160M	20.4	20.8	21.6	8.1	647	247	198	308	92.3	92.4	91.6	0.81	0.77	0.68	0.34	58
	970	D160L	21.1	21.6	22.5	8.8	597	215	197	295	91.4	92.2	91.9	0.79	0.74	0.64	0.59	65
	730	D180L	22.9	22.9	23.3	13.2	603	249	224	307	90.0	89.9	88.1	0.75	0.67	0.54	1.34	54
15	2925	D160M	24.9	25.8	27.6	6.1	699	205	136	307	92.3	92.7	92.1	0.91	0.89	0.84	0.20	73
	1465	D160L	28.0	28.5	29.5	11.3	674	280	230	305	92.5	92.7	91.9	0.81	0.76	0.67	0.40	58
	975	D180L	27.7	28.5	29.8	11.5	653	234	216	408	92.1	92.7	92.6	0.82	0.77	0.66	1.11	61
	735	D200L	30.5	31.1	32.2	14.8	564	244	220	249	91.8	91.9	91.1	0.75	0.69	0.57	2.67	60
18.5	2940	D160L	30.8	31.7	33.2	8.9	844	292	252	343	93.6	93.6	92.7	0.89	0.86	0.80	0.23	80
	1470	D180M	34.4	35.0	36.4	13.5	584	205	164	217	93.6	93.8	93.1	0.80	0.77	0.66	0.76	66
	975	D200L	32.1	33.2	34.9	11.6	623	346	299	372	92.5	93.3	93.4	0.87	0.83	0.75	1.99	65
	730	D225S	40.4	40.8	42.3	20.5	500	224	202	232	91.1	91.5	90.8	0.70	0.64	0.52	3.61	62
22	2955	D180M	36.8	37.9	39.8	9.9	785	282	226	308	93.9	93.9	93.0	0.89	0.86	0.80	0.46	65
	1480	D180L	41.3	41.9	43.4	17.5	625	262	210	274	94.1	93.7	92.9	0.79	0.74	0.63	0.82	56
	980	D200L	39.6	40.6	42.4	15.9	626	319	288	358	93.4	93.8	93.4	0.83	0.78	0.68	2.29	59
	735	D225M	43.0	43.7	44.8	23.4	700	279	237	297	91.9	92.0	90.9	0.77	0.70	0.57	4.21	66
30	2950	D200L	50.8	52.5	55.1	13.3	697	249	206	327	93.1	92.8	91.7	0.88	0.87	0.83	0.85	85
	1480	D200L	52.4	53.8	56.3	17.4	706	191	153	290	94.1	94.0	93.0	0.85	0.82	0.74	1.75	65
	980	D225M	53.2	54.8	57.3	17.9	624	260	229	391	94.3	94.7	94.6	0.83	0.80	0.72	3.57	67
	735	D250S	58.0	59.6	62.4	23.9	583	181	163	253	93.1	93.4	92.9	0.77	0.73	0.63	7.57	72



PERFORMANCE DATA

PREMIUM EFFICIENCY PERFORMANCE DATA AT 415V - 50Hz

Output kW	RPM	Frame Number	Full Load Current (A)			No Load Current (A)	Locked Rotor Current (%) F/L	Locked Rotor Torque (%) F/L	Pull Up Torque (%) F/L	Break Down Torque (%) F/L	Efficiency (%)			Power Factor			Rotor GD ² (kg.m ²)	Sound Pressure dB(A) at 1 metre
			@ 415V	@ 400V	@ 380V						Full Load	75% Load	50% Load	Full Load	75% Load	50% Load		
37	2950	D200L	61	63	67	15	690	311	254	390	94.0	94.1	93.8	0.89	0.88	0.86	1.02	84
	1480	D225S	68	69	72	27	705	210	168	314	94.6	94.5	93.8	0.80	0.75	0.66	2.27	67
	985	D250S	67	69	73	23	561	277	252	336	94.5	94.8	94.6	0.81	0.78	0.70	5.95	71
	740	D250M	73	74	76	34	633	188	169	228	93.5	93.7	93.0	0.75	0.70	0.58	8.83	66
45	2965	D225M	74	76	80	17	763	242	210	476	94.4	94.2	93.3	0.90	0.89	0.84	1.70	84
	1480	D225M	80	82	86	27	650	219	180	346	95.1	95.3	94.3	0.82	0.80	0.70	2.56	66
	985	D250M	83	84	88	33	669	353	282	354	94.9	94.9	94.4	0.80	0.75	0.65	7.28	66
	740	D280S	87	89	93	37	641	262	210	316	93.7	93.8	93.0	0.77	0.72	0.62	14.1	55
55	2965	D250S	91	94	100	23	682	217	210	397	94.4	94.2	93.3	0.89	0.87	0.83	3.2	82
	1480	D250S	98	100	104	34	716	204	219	163	94.4	94.2	93.3	0.83	0.79	0.71	4.2	72
	990	D280S	99	102	107	34	670	231	218	380	95.4	95.5	95.0	0.81	0.78	0.70	10.8	67
	740	D280M	107	109	114	48	678	204	176	223	94.2	94.3	93.6	0.76	0.71	0.60	18.2	58
75	2960	D250M	125	127	134	31	768	199	193	285	94.9	94.9	94.3	0.89	0.87	0.83	4.0	82
	1485	D250M	131	134	139	44	741	200	175	280	95.6	95.9	95.9	0.84	0.80	0.74	5.4	68
	990	D280M	139	143	148	43	639	227	215	405	95.6	95.9	95.8	0.78	0.76	0.68	14.8	69
	740	D315S	140	144	150	53	679	282	240	360	94.1	94.6	94.4	0.80	0.76	0.66	21.7	57
90	2980	D280S	149	150	157	31	735	161	150	276	96.0	95.7	95.0	0.90	0.89	0.84	4.6	82
	1485	D280S	151	155	164	40	699	178	134	246	95.6	95.5	94.7	0.87	0.85	0.80	8.8	77
	985	D315S	158	163	171	52	659	248	210	263	95.6	95.8	95.3	0.83	0.80	0.72	18.0	70
	745	D315M	173	175	180	84	656	254	229	311	94.7	94.5	93.5	0.77	0.70	0.58	27.8	63
110	2980	D280M	176	181	188	43	904	212	201	347	96.2	96.0	95.1	0.91	0.88	0.82	5.8	82
	1470	D280M	179	185	194	46	716	261	214	282	95.3	95.3	94.6	0.91	0.89	0.84	10.6	75
	985	D315M	193	199	209	60	664	197	180	296	95.7	95.8	95.4	0.83	0.80	0.73	20.1	74
132	2970	D315S	210	218	230	42	825	175	156	374	95.5	95.4	94.8	0.92	0.91	0.88	6.8	83
	1485	D315S	224	233	247	41	602	255	193	205	95.5	95.7	95.3	0.86	0.86	0.82	13.1	80
	985	D315M	230	237	248	73	677	215	187	273	95.6	96.0	95.5	0.83	0.81	0.73	22.8	70
150	2970	D315M	236	245	260	39	725	153	145	287	95.9	95.8	95.6	0.92	0.92	0.89	7.1	85
	1480	D315M	245	255	272	45	644	253	191	207	95.5	95.7	95.3	0.89	0.89	0.86	15.1	78
	985	D315M	263	272	285	86	741	253	208	310	95.8	96.0	95.6	0.83	0.80	0.73	19.1	71

HEAVY DUTY INDUSTRIAL - PREMIUM EFFICIENCY PERFORMANCE DATA AT 415V - 50Hz
 – LARGER SIZES (BEYOND AS 1359.30) AVAILABLE FROM STOCK

Output kW	RPM	Frame Number	Full Load Current (A)			No Load Current (A)	Locked Rotor Current (%) F/L	Locked Rotor Torque (%) F/L	Pull Up Torque (%) F/L	Break Down Torque (%) F/L	Efficiency (%)			Power Factor			Rotor GD ² (kg.m ²)	Sound Pressure dB(A) at 1 metre
			@ 415V	@ 400V	@ 380V						Full Load	75% Load	50% Load	Full Load	75% Load	50% Load		
185	1480	D315M(F)	310	322	339	88	553	186	161	223	95.0	94.9	94	0.88	0.86	0.80	25	81
200	2970	D315M(F)	332	331	348	76	602	210	168	260	95.2	94.9	93.7	0.89	0.88	0.84	16	87
	985	D315M(F)	371	376	384	178	624	212	180	252	95.0	95.1	94.2	0.79	0.73	0.61	27	79
220	1467	D315M(F)	375	387	407	115	531	204	177	237	94.8	94.8	93.8	0.87	0.85	0.78	25	84
250	2980	D315LL	430	430	404	120	733	255	170	295	95.9	95.9	95.2	0.90	0.88	0.81	24	89
	1458	D315LL	430	443	465	132	506	194	169	242	94.5	94.4	93.3	0.86	0.84	0.77	37	84
	985	D315LL	455	472	496	170	514	183	159	218	95.3	95.6	95.3	0.82	0.79	0.69	38	81
280	1468	D315LL	485	503	530	158	531	211	183	241	94.9	94.9	94.0	0.85	0.82	0.75	37	84
355	1475	D355LL	580	602	634	134	534	191	162	214	95.3	95.5	94.7	0.90	0.89	0.87	50	83

Note: For performance data on High Efficiency Motors >150kW, refer to page 14



DIMENSIONS - PREMIUM EFFICIENCY

FOOT MOUNTED

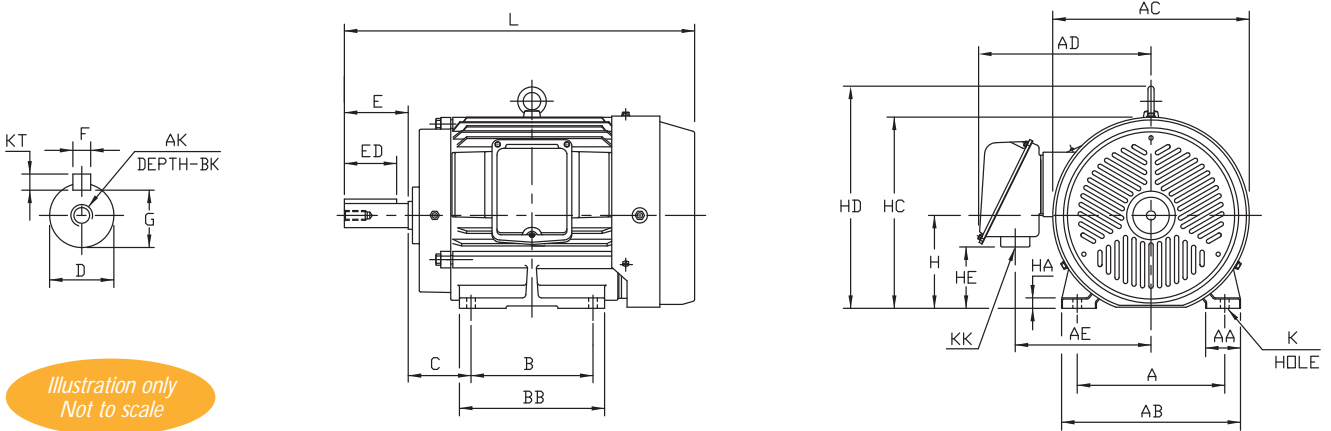

Illustration only
Not to scale

2, 4, 6, 8 POLE

ALL DIMENSIONS (MM)

DIMENSIONS	FRAME											
	D71	D80	D90SL	D90LL	D100L	D112ML	D132S	D132M	D160M	D160L	D180M	D180L
A	112	125	140	140	160	190	216	216	254	254	279	279
AA	35	35	40	40	45	40	50	50	60	60	60	60
AB	140	155	176	176	196	220	260	260	308	308	324	324
AC	160	180	207	207	223	242.5	284.5	284.5	324	324	390	390
AD	178	185	193	193	295	205	239	239	293	293	360	360
AE	135	145	142	142	166	158	181	181	220	220	275	275
AK	M5	M6	M8	M8	M10	M10	M12	M12	M16	M16	M16	M16
B	90	100	100	125	140	140	140	178	210	254	241	279
BB	114	130	149	178	176	187	175	213	250	294	286	324
BK	18	20	25	25	28	28	28	28	36	36	36	36
C	45	50	56	56	63	70	89	89	108	108	121	121
D	14	19	24	24	28	28	38	38	42	42	48	48
E	30	40	50	50	60	60	80	80	110	110	110	110
ED	22	30	40	40	50	50	65	65	90	90	90	90
F	5	6	8	8	8	8	10	10	12	12	14	14
G	11	15.5	20	20	24	24	33	33	37	37	42.5	42.5
H	71	80	90	90	100	112	132	132	160	160	180	180
HA	8	8	10	10	12	12	15	15	18	18	20	20
HC	162	175	198	198	-	-	-	-	-	-	-	-
HD	-	-	-	-	246	274	316	316	373	373	440	440
HE	31.5	43.5	27.3	27.3	69	55	67.5	67.5	92.5	92.5	98	98
K	7	10	10	10	12	12	12	12	14.5	14.5	14.5	14.5
KK	M20	M20	M20	M20	M20	M20	M25	M25	M32	M32	M40	M40
KT	5	6	7	7	7	7	8	8	8	8	9	9
L	234	274	327	356	376	401	450	488	603	647	677	715
WEIGHT**	17	24	26	29	44	53	113	85	136	158	205	217

** Weight is given in kg as an approximate value.



DIMENSIONS - PREMIUM EFFICIENCY

FOOT MOUNTED

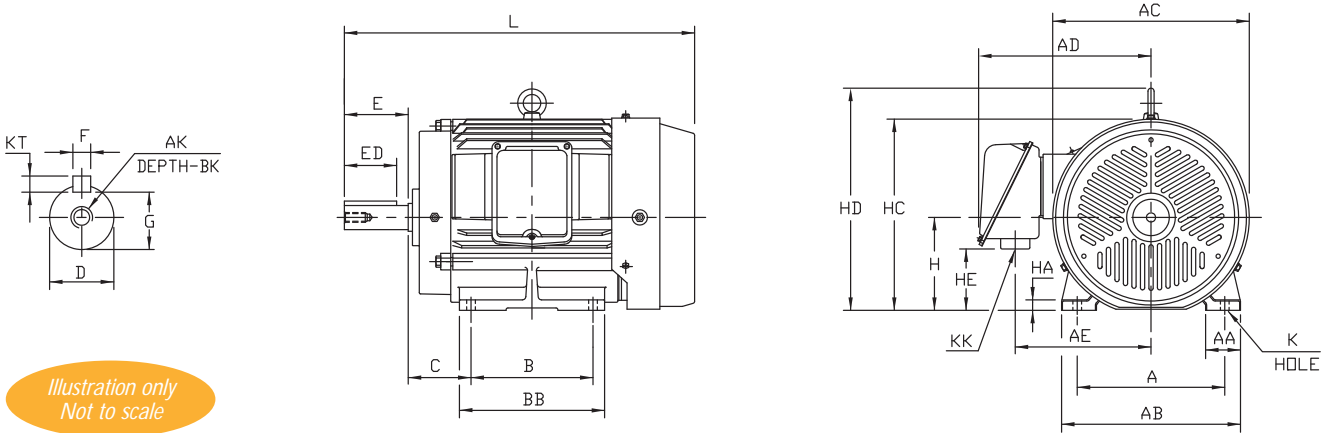

Illustration only
Not to scale

2, 4, 6, 8 POLE

ALL DIMENSIONS (MM)

DIMENSIONS	FRAME									LARGE FRAMES		
	D200L	D225S	D225M	D250S	D250M	D280S	D280M	D315S	D315M	D315M(F)	D315LL	D355LL
A	318	356	356	406	406	457	457	508	508	508	508	610
AA	80	80	80	100	100	110	110	140	140	140	140	160
AB	378	416	416	486	486	560	560	630	630	645	645	710
AC	441	484	484	547	547	621	621	680	680	800	800	860
AD	385	410	410	520	520	545	545	552	552	850	850	890
AE	300	325	325	403	403	428	428	443	443	618	618	658
AK	2	M20	M20	M20	M20	M20	M20	M20	M20	M20	M20	-
	4, 6, 8	M20	M20	M20	M20	M20	M20	M20	M20	M20	M24	M24
B	305	286	311	311	349	368	419	406	457	457	710	900
BB	360	366	391	415	449	440	490	480	530	530	782	1020
BK	42	42	42	42	42	42	42	42	42	30	36	36
C	133	149	149	168	168	190	190	216	216	216	216	254
D	2	55	-	55	60	60	65	65	65	65	65	-
	4, 6, 8	55	60	60	70	70	80	80	85	85	95	110
E	2	110	-	110	140	140	140	140	140	140	140	-
	4, 6, 8	110	140	140	140	140	170	170	170	170	210	210
ED	2	90	110	90	110	110	110	110	110	110	110	-
	4, 6, 8	90	110	110	110	110	140	140	140	140	170	170
F	2	16	-	16	18	18	18	18	18	18	18	-
	4, 6, 8	16	18	18	20	20	22	22	22	25	28	28
G	2	49	-	49	53	53	58	58	58	58	58	-
	4, 6, 8	49	53	53	62.5	62.5	71	71	76	76	86	100
H	200	225	225	250	250	280	280	315	315	315	315	355
HA	20	22	22	30	30	30	30	35	35	35	35	40
HC	-	-	-	-	-	-	-	-	-	-	-	-
HD	486	538	538	618	618	675	695	738	738	740	740	835
HE	143	173	173	81	81	127	127	63	63	33	33	75
K	18.5	18.5	18.5	24	24	24	24	28	28	28	28	28
KK	M50	M50	M50	M63	M63	M63	M63	M63	M63	NIL	NIL	NIL
KT	2	10	-	10	11	11	11	11	11	11	11	-
	4, 6, 8	10	11	11	12	12	14	14	14	14	16	16
L	2	772.5	-	812	946.5	984.5	1083.5	1134.5	1224	1275	1392	1501
	4, 6, 8	772.5	817	842	946.5	984.5	1113.5	1164.5	1341.5	1392.5	1434.5	1583.5
WEIGHT**	321	395	418	597	680	824	943	1107	1319	1800	2050	2780

** Weight is given in kg as an approximate value.



DIMENSIONS - PREMIUM EFFICIENCY

FOOT & FLANGE MOUNTED

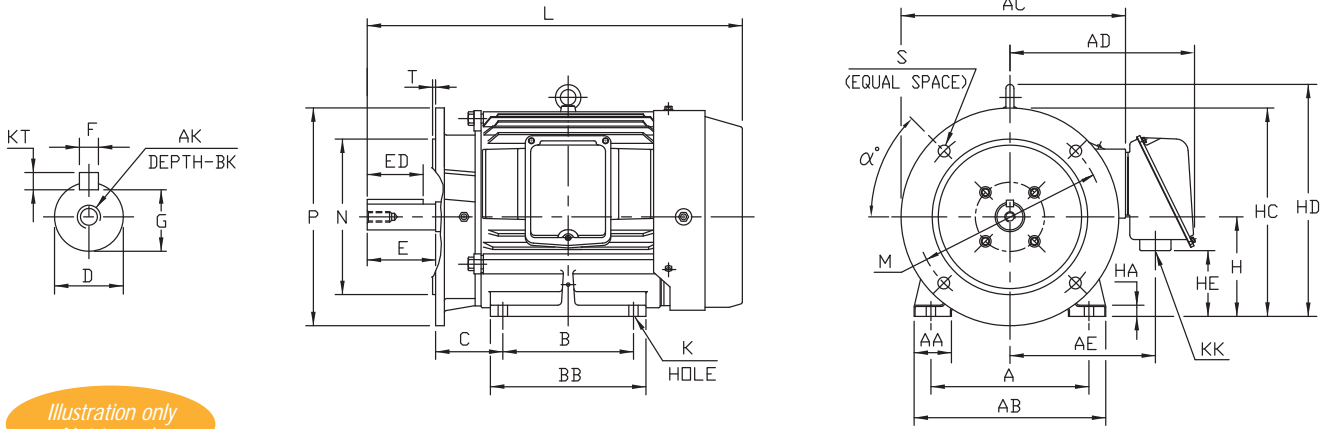

Illustration only
Not to scale

Flanges D71–D200 4 hole fixing
Flanges D225–D315 8 hole fixing

2, 4, 6, 8 POLE

ALL DIMENSIONS (MM)

DIMENSIONS	FRAME											
	D71	D80	D90SL	D90LL	D100L	D112ML	D132S	D132M	D160M	D160L	D180M	D180L
A	112	125	140	140	160	190	216	216	254	254	279	279
AA	35	35	40	40	45	40	50	50	60	60	60	60
AB	140	155	176	176	196	220	260	260	308	308	324	324
AC	–	184	207	207	223	243	284.5	284.5	350	350	390	390
AD	178	185	192.5	192.5	210	205	239	239	293	293	360	360
AE	135	144.5	142	142	167	158	181	181	220	220	275	275
AK	M5	M6	M8	M8	M10	M10	M12	M12	M16	M16	M16	M16
B	90	100	100	125	140	140	140	178	210	254	241	279
BB	114	130	149	178	176	187	175	213	250	294	286	324
BK	18	20	25	25	28	28	28	28	36	36	36	36
C	74	50	56	56	63	70	89	89	108	108	121	121
D	14	19	24	24	28	28	38	38	42	42	48	48
E	30	40	50	50	60	60	80	80	110	110	110	110
ED	22	30	40	40	50	50	65	65	90	90	90	90
F	5	6	8	8	8	8	10	10	12	12	14	14
G	11	15.5	20	20	24	24	33	33	37	37	42.5	42.5
H	71	80	90	90	100	112	132	132	160	160	180	180
HA	8	8	10	10	12	12	15	15	18	18	20	20
HC	162	175	198	198	–	–	–	–	–	–	–	–
HD	–	–	–	–	246	274	316	316	373	373	440	440
HE	31.5	43.5	41	41	58	61	67.5	67.5	92.5	92.5	106	106
K	7	10	10	10	12	12	12	12	14.5	14.5	14.5	14.5
KK	M20	M20	M20	M20	M20	M20	M25	M25	M32	M32	M40	M40
KT	5	6	7	7	7	7	8	8	8	8	9	9
L	273	274	327	356	369	401	450	488	603	647	676.5	714.5
M	130	165	165	165	215	215	265	265	300	300	300	300
N	110	130	130	130	180	180	230	230	250	250	250	250
P	160	200	200	200	250	250	300	300	350	350	350	350
S	10	12	12	12	14.5	14.5	14.5	14.5	18.5	18.5	18.5	18.5
T	3.5	3.5	3.5	3.5	4	4	4	4	5	5	5	5
HOLES	4	4	4	4	4	4	4	4	4	4	4	4
WEIGHT**	18	26	28	31	49	57	85	117	144	166	215	227

** Weight is given in kg as an approximate value.

Angle α° for 4 hole = 45° , 8 hole = 22.5° .



DIMENSIONS - PREMIUM EFFICIENCY

FOOT & FLANGE MOUNTED

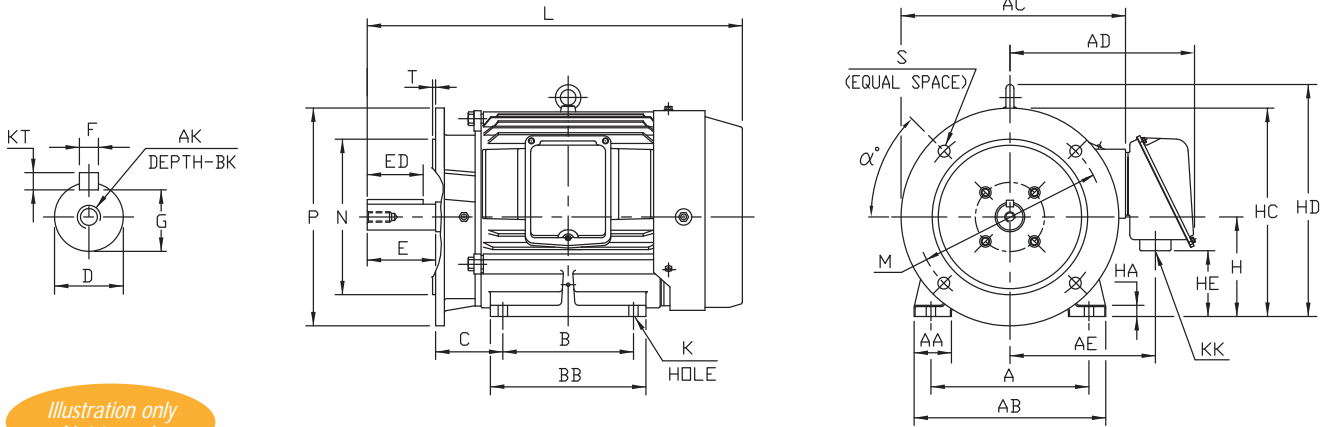

Illustration only
Not to scale

Flanges D71–D200 4 hole fixing
Flanges D225–D315 8 hole fixing

2, 4, 6, 8 POLE

ALL DIMENSIONS (MM)

DIMENSIONS	FRAME									LARGE FRAME			
	D200L	D225S	D225M	D250S	D250M	D280S	D280M	D315S	D315M	D315M(F)	D315LL	D355LL	
A	318	356	356	406	406	457	457	508	508	508	508	610	
AA	80	80	80	100	100	110	110	140	140	140	140	160	
AB	378	416	416	486	486	560	560	630	630	630	645	710	
AC	441	N/A	N/A	N/A	547	621	621	680	680	760	800	860	
AD	385	410	410	520	520	545	545	552	552	862	850	890	
AE	300	325	325	403	403	428	428	443	443	628	618	658	
AK	2	M20	–	M20	M20	M20	M20	M20	M20	M24	M24	M24	
	4, 6, 8	M20	M20	M20	M20	M20	M20	M20	M24	M24	M24	M24	
B	305	286	311	311	349	368	419	406	457	457	710	900	
BB	360	366	391	415	449	440	490	480	530	530	782	1020	
BK	42	42	42	42	42	42	42	42	42	36	36	36	
C	133	149	149	168	168	190	190	216	216	216	216	254	
D	2	55	55	55	60	60	65	65	65	65	65	65	
	4, 6, 8	55	60	60	70	70	80	80	85	85	95	110	
E	2	110	110	110	140	140	140	140	140	140	140	140	
	4, 6, 8	110	140	140	140	140	170	170	170	170	210	210	
ED	2	90	90	90	110	110	110	110	110	110	110	110	
	4, 6, 8	90	110	110	110	110	140	140	140	140	170	170	
F	2	16	16	16	18	18	18	18	18	18	18	18	
	4, 6, 8	16	18	18	20	20	22	22	22	25	28	28	
G	2	49	49	49	53	53	58	58	58	58	58	58	
	4, 6, 8	49	53	53	62.5	62.5	71	71	76	86	100	100	
H	200	225	225	250	250	280	280	315	315	315	315	355	
HA	25	22	22	30	30	30	30	35	35	34	35	40	
HD	486	538	538	618	618	675	670	738	738	735	740	835	
HE	143	172	173	81	81	127	127	63	63	33	33	75	
K	18.5	18.5	18.5	24	24	24	24	28	28	28	28	28	
KK	M50	M50	M50	M63	M63	M63	M63	M63	M63	NIL	NIL	NIL	
KT	2	10	10	10	11	11	11	11	11	11	11	11	
	4, 6, 8	10	11	11	12	12	14	14	14	14	16	16	
L	2	772.5	772	812	946.5	984.5	1135	1135	1330	1303	1392	1433.5	1965
	4, 6, 8	772.5	817	842	946.5	984.5	1165	1165	1342	1393	1434.5	1583.5	1900
M	350	400	400	500	500	500	500	600	600	600	600	740	
N	300	350	350	450	450	450	450	550	550	550	550	680	
P	400	450	450	550	550	550	550	660	660	660	660	800	
S	18.5	18.5	18.5	18.5	18.5	18.5	18.5	24	24	24	24	24	
T	5	5	5	5	5	5	5	6	6	6	6	6	
HOLES	4	8	8	8	8	8	8	8	8	8	8	8	
WEIGHT**	329	416	439	627	710	844	963	1143	1355	1836	2100	2840	

** Weight is given in kg as an approximate value.

Angle α° for 4 hole = 45° , 8 hole = 22.5° .



PERFORMANCE DATA

HIGH EFFICIENCY PERFORMANCE DATA AT 415V - 50Hz

LARGER SIZES (BEYOND AS 1359.30) AVAILABLE FROM STOCK

Output kW	RPM	Frame Number	Full Load Current (A)			No Load Current (A)	Locked Rotor Current (%) F/L	Locked Rotor Torque (%) F/L	Pull Up Torque (%) F/L	Break Down Torque (%) F/L	Efficiency (%)			Power Factor			Rotor GD ² (kg.m ²)	Sound Pressure dB(A) at 1 metre*
			@ 415V	@ 400V	@ 380V						Full Load	75% Load	50% Load	Full Load	75% Load	50% Load		
185	2955	D315M(F)	295	306	322	62	678	152	134	273	95.7	95.5	94.5	0.92	0.91	0.87	16	85
	1480	D315M(F)	310	322	332	66	600	175	152	226	95.9	96.1	95.5	0.87	0.86	0.82	25	82
	985	D315M(F)	314	387	407	99	637	140	119	225	95.9	96.0	95.0	0.86	0.84	0.78	27	83
200	2955	D315LL	323	335	335	54	619	143	126	243	95.5	95.3	94.8	0.92	0.92	0.90	16	85
	1480	D315M(F)	316	TBA	TBA	52	661	128	110	260	95.9	96.1	95.5	0.93	0.93	0.90	25	80
	985	D315M(F)	339	TBA	TBA	111	649	136	116	230	96.0	95.9	95.5	0.85	0.83	0.76	27	82
220	2955	D315LL	348	361	380	64	661	152	134	272	95.9	95.8	95.0	0.93	0.92	0.88	24	85
	1480	D315M(F)	347	360	379	52	605	117	98	235	95.7	96.2	96.0	0.93	0.93	0.91	25	80
	985	D315LL	373	TBA	TBA	152	670	142	120	238	95.7	95.6	95.0	0.84	0.80	0.71	38	79
250	2955	D315LL	396	410	431	75	679	140	120	270	95.8	95.9	95.1	0.92	0.92	0.88	24	85
	1485	D315LL	396	411	432	57	626	130	110	227	95.9	96.3	96.2	0.92	0.94	0.92	37	78
	985	D315LL	421	437	460	166	641	140	120	235	96.0	95.5	95.0	0.84	0.81	0.72	38	83
280	1480	D315LL	432	459	483	76	773	166	125	260	95.9	96.0	95.5	0.94	0.93	0.91	37	81
315	1485	D355LL	498	517	544	75	592	131	110	210	95.5	95.8	95.4	0.92	0.93	0.91	50	82
355	1485	D355LL	559	TBA	TBA	83	603	148	126	207	95.8	96.1	95.8	0.92	0.93	0.91	50	80

BEARING INFORMATION

BEARINGS FOR PREMIUM EFFICIENCY MOTORS

Frame Number	D71	D80	D90S	D90L	D100L	D112M	D132S, M	D160M, L		D180M, L		D200L	
Poles	2, 4, 6, 8	2, 4, 6, 8	2, 4, 6, 8	2, 4, 6, 8	2, 4, 6, 8	2, 4, 6, 8	2, 4, 6, 8	2	4, 6, 8	2	4, 6, 8	2	4, 6, 8
Drive End	6203ZZ	6204ZZ	6205ZZ	6205ZZ	6206ZZ	6207ZZ	6308ZZ	6310C3	6310	6310C3	6310	6312C3	6312
Non-Drive End	6203ZZ	6204ZZ	6205ZZ	6205ZZ	6206ZZ	6206ZZ	6208ZZ	6208C3	6208	6210C3	6210	6212C3	6212

Frame Number	D225S, M		D250S, M		D280S, M		D315S, M		D315M		D315LL		D355LL
Poles	2	4, 6	2	4, 6	2	4, 6	2	4, 6	2	4, 6	2	4, 6	4, 6
Drive End	6312C3	NU215	6313C3	NU218	6314C3	NU220	6314C3	NU320	6314C3	NU2224	6314C3	NU2224	NU2224
Non-Drive End	6312C3	6312	6313C3	6313	6313C3	6315	6313C3	6318	6313C3	6318	6313C3	6318	6320

RE-GREASING INFORMATION TABLE

Bearing No.	Grease Qty (Grams)	Replenish Intervals (days)			
		2P	4P	6P	8P
6208	25	70	130	130	130
6209	25	70	130	130	130
6210	30	70	130	130	130
6211	30	70	130	130	130
6212	30	70	130	130	130
6213	30	50	130	130	130
6214	30	50	130	130	130
6310	30	50	130	130	130
6311	30	50	130	130	130
6312	30	50	130	130	130
6313	30	50	130	130	130
6314	50	40	100	130	130
6315	50	40	100	130	130
6316	50	40	100	130	130

Bearing No.	Grease Qty (Grams)	Replenish Intervals (days)			
		2P	4P	6P	8P
6317	80	N/A	100	130	130
6318	80	N/A	100	130	130
6319	80	N/A	100	130	130
6320	80	N/A	100	130	130
NU214	30	N/A	100	130	130
NU215	30	N/A	100	130	130
NU216	30	N/A	100	130	130
NU216	30	N/A	100	130	130
NU218	30	N/A	100	130	130
NU219	50	N/A	100	130	130
NU220	50	50	100	130	130
NU318	80	40	70	130	130
NU320	80	40	50	130	130
NU2224	115	30	80	115	130

Note: the above table is based on a motor running for 24 hours per day. For an 8-hour duty cycle multiply the interval by 3.

RE-GREASING

Motors with grease nipples will require periodic re-greasing. When re-greasing, use only recommended grease indicated below. The motor must be running and have grease exit ports opened during lubrication. For motors requiring special types of lubricant, the specification and quantity of grease to be used are noted on the nameplate. Motors without greasing facilities are fitted with sealed bearings. Sealed bearings are pre-lubricated for the life of the bearing but should be monitored by the user and replaced when necessary.

RECOMMENDED GREASE

Toshiba recommends the use of Shell Alvania RL 2 and RL 3 lithium based grease. Always regrease bearings with the same grease type.

Note: Excess lubrication and/or incorrect grease type may cause an increase in bearing temperature. This may lead to an increased risk of premature bearing failure.

Note: When regreasing a running motor ensure all safety precautions are observed. Ensure that the motor runs for a sufficient time to allow the used grease to purge before the exit ports are reclosed.



AVAILABLE CUSTOMISATION OPTIONS	
Anti Condensation heaters	Left hand side terminal box
Bearing change on Non drive – end	Lifting lugs – Special fittings
Bearing change on Drive – end	Low noise fans
Bearing RTDs	Oil seals
Bearing sensors	Painting to special colours – Enamel
Brass gland plate	Painting to special colours – Epoxy
Blank identification nameplate	Painting to special colours – Polyurethane
Captive screws for terminal box lids	Porous (sintered bronze) drain plugs
Cast iron fan cover	Rain hats
Constant velocity cooling fan	Re-nameplate
Dual hand terminal boxes	Routine test (non-witnessed)
Earth brush and Insulated Non – drive end housing for VSD applications	Routine test (witnessed)
Encoders	Shaft down application modifications
Earth studs – Additional	Shaft up application modifications
Feet removal	Separate terminal box auxiliary connections
Flange fitting	Special non standard shafts and extensions
Hazardous areas upgrades – Dust-excluding Ignition Proof (DIP)	Special voltage applications
Hazardous areas upgrades – Increased Safety (Ex-e)	Stainless steel coal shield
Hazardous areas upgrades – Non Sparking (Ex-n)	Stainless steel fan covers
Fail safe brake motors	Stainless steel sunshield
High grade balancing	Stainless steel fasteners
Isonel Winding (tropic proofing)	Thermistors terminated in auxiliary box
IP65/IP66 protection rating upgrades	Winding RTDs terminated in auxiliary box
B14A Flanges available	

PAINTING

A typical customer modification is an enhanced painting system, where a specification requires environmentally friendly low VOC, isocyanate free, superior corrosive protection, improved aesthetics, and extended durability, we offer different systems to meet your requirements.



Performance of a paint coating is influenced by a number of variables including atmospheric aggressiveness, surface preparation and the type and thickness of paint.

TIC is capable of offering three paint systems dependant on your requirements:

- Acrylic high gloss finish, isocyanate free, weather resistant finish.
- Epoxy, semi gloss, low VOC, high solids paint, providing an excellent anti-corrosive barrier protection.
- TIC actively promotes the use of environmentally sensitive products and also offer Polysiloxane, a premium high performance, high solid, very low VOC, superior gloss, anti corrosive painting product.

The minimum dry film thickness is clearly a function of the required duration and life cycle, but only to a certain practical point, a maximum of 210 microns for the harshest of conditions is recommended. Contact your local Toshiba International Corporation office for further information.

The most common requested colours:



RAL 7003
Moss Grey



Y14
Golden Yellow



B24
Harbour Blue



R64



X15
Orange



G22
Serpentine

ADDITIONAL PRODUCTS

(Detailed catalogues available)



Variable Speed Drives
(0.4kW – 630kW)



Electronic Soft Starters
(7.5kW – 3MW)



Large Drives/Drive Systems



Protection Relay

After Sales Service
Plant Maintenance & Monitoring
Asset Management
Plant Alliance Management



Microwave Density Meter

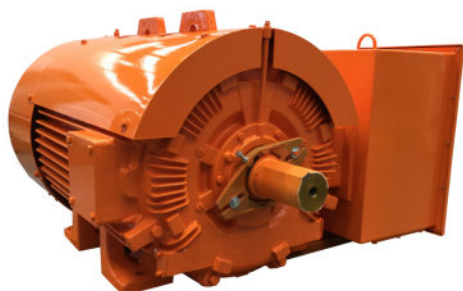

Heavy Duty Motor



Explosion Protected Motor



High Voltage AC Motor

TOSHIBA

NSW/SYDNEY - Registered Office

Toshiba International Corporation Pty Ltd
11A Gibbon Road,
Winston Hills, NSW 2153
Tel: +61 2 8867 6200 Fax: +61 2 9624 7104

NSW/MAITLAND

Toshiba International Corporation Pty Ltd
Unit 1, 18 Kinta Drive
Beresfield NSW 2322
Ph: +61 2 4966 8124 Fax: +61 2 4966 8147

QUEENSLAND

Toshiba International Corporation Pty Ltd
Level 2 / 7 Clunies Ross Court,
Eight Mile Plains, QLD 4113
Ph: +61 7 3909 9000 Fax: +61 7 3841 1121

VICTORIA

Toshiba International Corporation Pty Ltd
Suite 105, 189 South Centre Road,
Tullamarine, VIC 3043
Tel: +61 3 9538 1800 Fax: +61 3 9583 1899

WESTERN AUSTRALIA

Toshiba International Corporation Pty Ltd
30 Anderson Place,
Perth International Airport, WA 6105
Tel: +61 8 6272 5600 Fax: +61 8 6272 5601

www.toshiba.com.au

Toshiba International Corporation Pty Ltd ABN: 29 001 555 068
The information in this brochure is subject to change without notice. 05/19

Distributed by:

Drive Solutions NQ PTY LTD
www.drivesolutions.com.au
email: support@drivesolutions.com.au
Ph: (07) 4091-7302
Mob: 0439-307-015